

CWS09CP

IMPORTANT: Measure project dimensions starting from the glass edge.

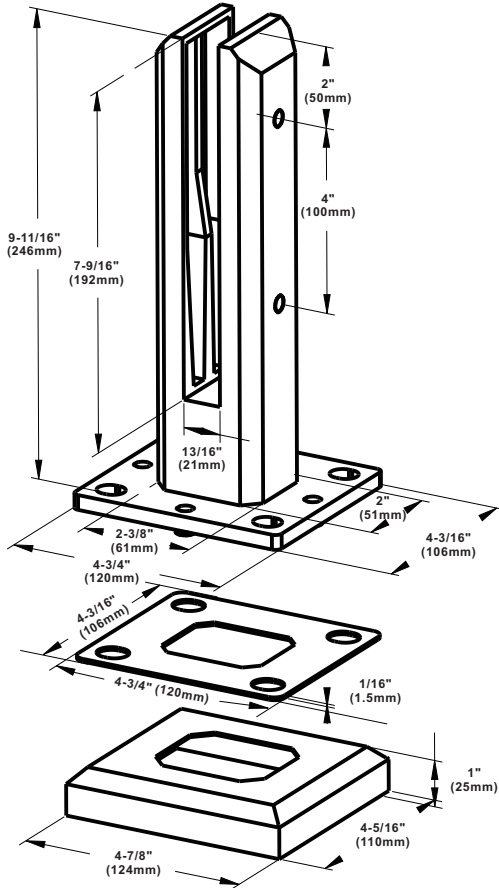

*Not shown to scale.



Item Number	Glass size
CWS09CP	1/2" (12mm) - 9/16" (14mm)

Stainless Steel Advisory:

Stainless steel is a durable chromium and nickel-based alloy that offers superior corrosion resistance. However, stainless steel is not stain or rust proof. Environmental conditions, such as proximity to large bodies of water, can be contributing factors to corrosion. Stainless steel can also discolor, rust, or corrode if it's in regular contact with chloride salts, sulfides, or rusting metals such as iron. Lastly, metal cutting equipment including chop saws can leave small metal deposits on stainless steel that may lead to rusting if not properly removed.

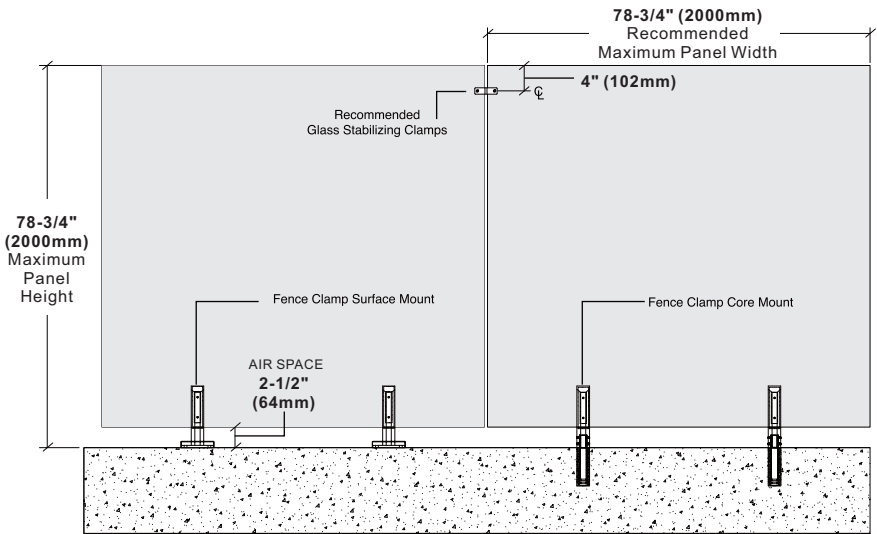

***IMPORTANT:** Measure project dimensions starting from the glass edge.

***Not shown to scale.**

Specifications:

Glass Sizes: 1/2" (12mm) to 9/16" (14mm) thick tempered safety glass
Includes: Gaskets, template

Construction: 2205 Stainless Steel

Maximum Glass Capacities for Two Post

Weight bearing capacity: 1763 lbs. (800kg)

Side column force: 882 lbs. (400kg)

Recommendations:

To ensure public safety, we strongly advise using only tempered safety glass. Not for guardrail applications.

UNIKOO LIMITED WARRANTY:

- UNIKOO warrants its commercial hardware for a period of 1 year from the date of purchase. UNIKOO commercial hardware is warranted against material and workmanship defects.
- All warranty claims are subject to inspection by UNIKOO before providing a resolution against the warranty claim.
- This warranty is void if it is determined after UNIKOO inspection that the Hardware has been improperly installed and/or maintained in a manner not conforming to UNIKOO guidelines and instructions provided at time of purchase.
- UNIKOO's responsibility to provide a resolution under said warranty will be limited to a refund of purchased price or provide a replacement for the hardware.
- The refund or replacement will constitute UNIKOO's limited liability and obligation for any and all defective material/workmanship for said warranty claim.
- THIS WARRANTY IS EXCLUSIVE AND UNIKOO MAKES NO OTHER WARRANTY, EXPRESSED OR IMPLIED.